

Packaged Aqualoop GW1800L

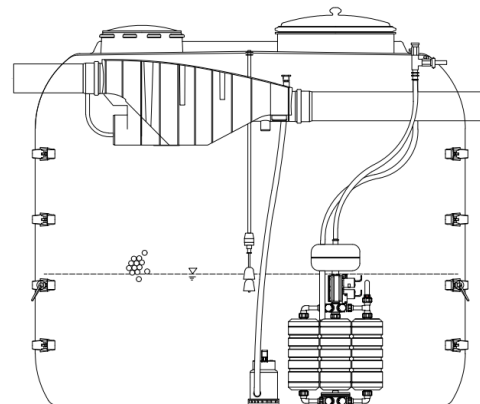

Certified to NSF/ANSI
Standard 350



Description

Aqualoop pre-assembled, packaged systems minimize engineering, installation, commissioning, and start-up time for an overall reduced installed cost. Each fully-assembled system is shipped shop-tested and ready for electrical and plumbing hook-up; with a complete drawing set, submittal package, and O&M manual.

Aqualoop commercial greywater treatment systems can be scaled to produce superior water quality at any capacity. With its NSF 350(C) certification, Aqualoop treats greywater for indoor and outdoor non-potable uses such as toilet flushing, laundry, spray irrigation, and cooling tower make up. Aqualoop's patented and NSF certified MBR technology assures high water quality with low maintenance. The technology is scalable to any capacity, while retaining the NSF 350(C) certification, by installing multiple units in parallel.

Specification

Specifications		
Model Number	GW1800L (See note 1)	
NSF Listed Daily Average Capacity (See note 2)	476 GPD	
Approved Source Water (See note 2)	NSF 350 Bath-Laundry Challenge Greywater Quality, Max. 180 PPM BOD, 100 PPM TSS	
	Bioreactor Tank	NSF 350 Holding Tank (See note 3)
Bioreactor Tank Working Volume	378 Gallons	291 Gallons
Bioreactor Tank Capacity	794 Gallons	291 Gallons
Bioreactor Tank Length	92"	55"
Bioreactor Tank Width	33"	28"
Tank Height'	78"	54"
Tank Overflow Diameter	6"	2"
Tank Material	HDPE	
Controller (See note 4)	Standard	
BMS Connection	None	
Pre-Filtration (See note 4)	Intewa PURAIN DN150 with Automatic Cleaning Shower	
Greywater Inlet Diameter	6"	
Tank Overflow Diameter	6"	
Growth Media	360 Liters	
Air Scour Blower Sizing (See note 4)	200 LPM	
Membrane Clean-In-Place	Semi-Automatic	

Notes:

1. Parallel stand-alone units can be used to scale to larger systems within NSF 350 requirements.
2. See listing at <http://info.nsf.org/Certified/Wastewater/Listings.asp?TradeName=Aqualoop&Standard=>
3. Larger holding tank sizes are available.
4. See separate Specifications for details of – PURAIN Pre-filter, Controller, Blowers, and Membrane Station

SPECIFICATION SHEET

Packaged Aqualoop GW1800L

Technical Overview

- *The GW1800L comes fully assembled with tanks and simply requires water connection and electrical connection to be up and running with minimal installation time and cost.*
- *Treated water for toilets, cooling tower, laundry, spray irrigation*
- *Aqualoop is currently the ONLY NSF 350(C) certified system for greywater recycling.*
- *NSF 350 certification reached with biological treatment and ultrafiltration (Moving Bed MBR)*
 - *Pre-screening with PURAIN Pre-Filter*
 - *Biological treatment using aeration and growth media in a moving bed*
 - *Patented hollow fiber membrane cartridge ultra-filtration disinfection to 0.02 microns*
 - *Additional disinfection not required in certification. Can be added for specialized needs.*
- *CAD schematic drawings available at <https://www.ecoviewwater.com/technical-library/>*



Certified to NSF/ANSI
Standard 350

Major Components

GW1800L Bioreactor Detail

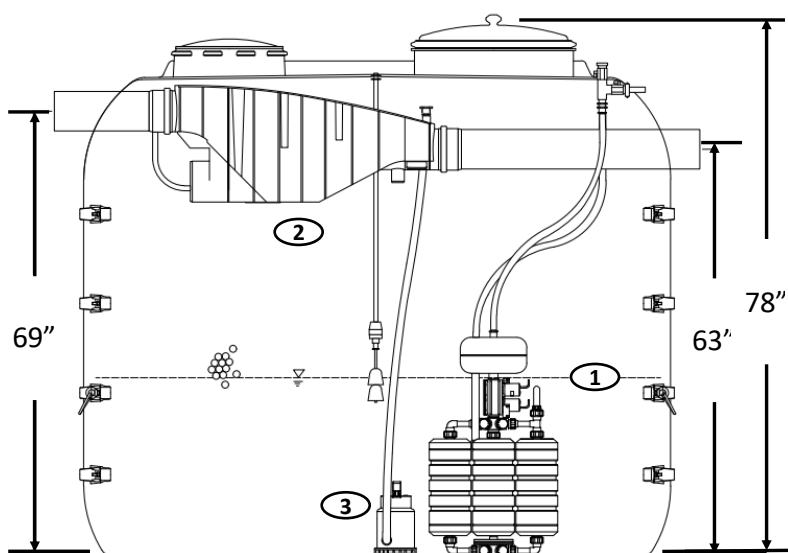

- ① Membrane Station – Includes membrane cartridges, 0.02 micron ultrafilter, transfer/backwash pump module, air scour inlet
- ② PURAIN DN150 Pre-Filter – Auto-Shower, 6" Inlet/Outlet
- ③ Sludge Pump – 30 GPM, wired to controller, programmed discharge

SPECIFICATION SHEET

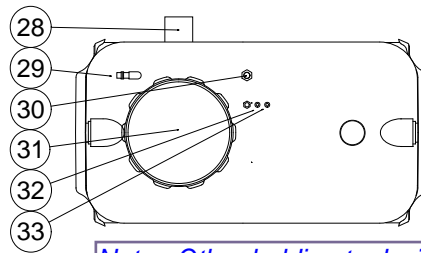
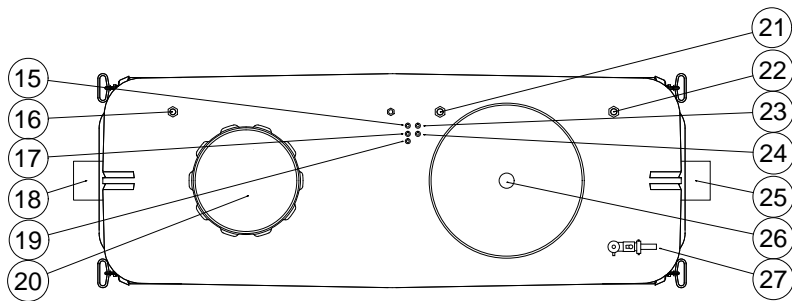
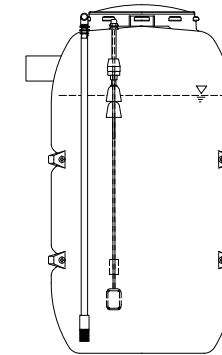
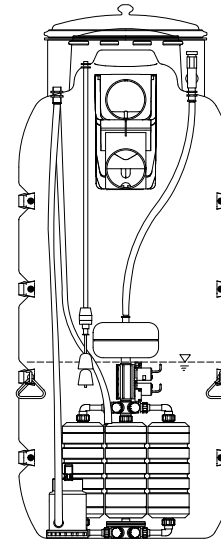
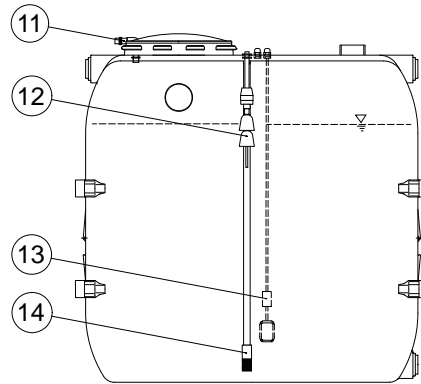
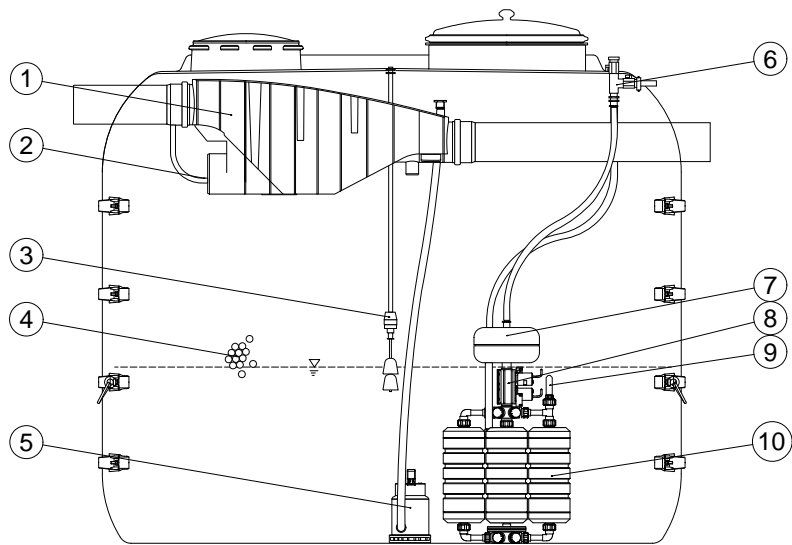

Note: Other holding tank sizes are available.

Components

- | | |
|-------------------------------------|--|
| 1. PURAIN prefilter | 8. Filtration and backwash pumps |
| 2. PURAIN backflush nozzle | 9. Membrane pressure sensor |
| 3. Floating switch, BR min | 10. Ultrafiltration cartridge |
| 4. Growth carriers | 11. Filtrate connection |
| 5. Sludge pump | 12. Floating switch, CL max |
| 6. Filtrate and cleaning connection | 13. Floating switch, incl. with RAINMASTER |
| 7. Backwash tank | 14. Suction filter |

Connections (to AQUALOOP controller)

- 15. Floating switch (Float-Sw BR min)
- 16. PURAIN backflush, 3/4" OD
- 17. Sludge pump (230V-SLUDGE)
- 18. Greywater inlet, DN150
- 19. Membrane pressure sensor (ADr-Pump)
- 20. Opening, Ø400 mm
- 21. Sludge pump outlet, 1" OD
- 22. Blower, 1" OD
- 23. Filtration pump (Pump Suction)
- 24. Backwash pump (Pump Backflush)
- 25. Greywater overflow, DN150
- 26. Opening, Ø600 mm
- 27. Filtrate and cleaning, 3/4" OD
- 28. Clear water overflow, DN100
- 29. Filtrate inlet, 3/4" OD
- 30. Suction filter outlet, 1" OD
- 31. Opening, Ø400 mm
- 32. Floating switch (Float-SW CL max)
- 33. RAINMASTER floating switch

**Product: AQUALOOP greywater recycling system
1800 L/day**

INTEWA GmbH

Product Name: AL-GW600 System
Product code: 230205

*Incl. but not shown: AQUALOOP Controller and Blower