

Note: Other holding tank sizes are available.

Connections

- 19. PURAIN backflush, 3/4" OD
- 20. Opening for pre-filter PURAIN, Ø400 mm
- 21. Greywater inlet, DN150
- 22. Opening, Ø600 mm
- 23. Level sensor (BR min)
- 24. Filtration pump (Pump Suction)
- 25. Sludge pump outlet, 1" OD
- 26. Blower Diffuser, 1" OD
- 27. Bio reactor overflow, DN150
- 28. Opening, Ø600 mm
- 29. Backwash pump (Pump Backflush)
- 30. Sludge pump (230V-SLUDGE)
- 31. Blower Membrane, 1" OD
- 32. Filtrate and cleaning, 3/4" OD
- 33. Opening, Ø500 mm
- 34. Suction filter outlet, 1 1/2" OD
- 35. Filtrate inlet, 3/4" OD
- 36. Clear water overflow, DN100
- 37. RAINMASTER floating switch
- 38. Level sensor (CL max)

Components

- 1. PURAIN prefilter
- 2. PURAIN backflush nozzle
- 3. Backwash tank
- 4. Growth carriers
- 5. Filtration and backwash pumps
- 6. Sludge pump
- 7. Level sensor, BR min
- 8. Aeration Diffuser
- 9. Filtrate and cleaning connection
- 10. Ultrafiltration cartridge
- 11. Filtrate connection inlet
- 12. Level sensor, CL max
- 13. Floating switch (for e.g. booster pump RM)
- 14. Suction filter for booster pump
- 15. Blower Diffuser
- 16. Blower Membrane station
- 17. Automatic cleaning device
- 18. Controller incl. remote control

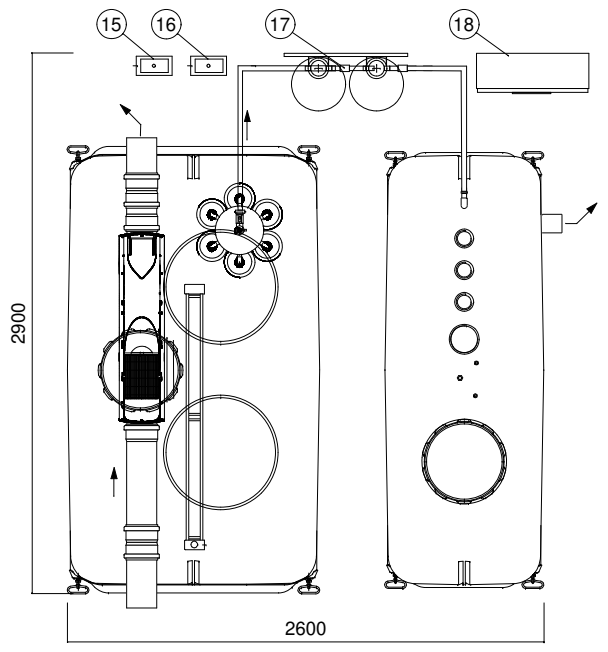

Product: **AQUALOOP** greywater recycling system
 5400 L/day with A-CIP
INTEWA GmbH
 Product Name: AL-GW5400 A-CIP System
 Product code: